

REMINGTON®

ELECTRIC CHAIN SAW OWNER'S MANUAL

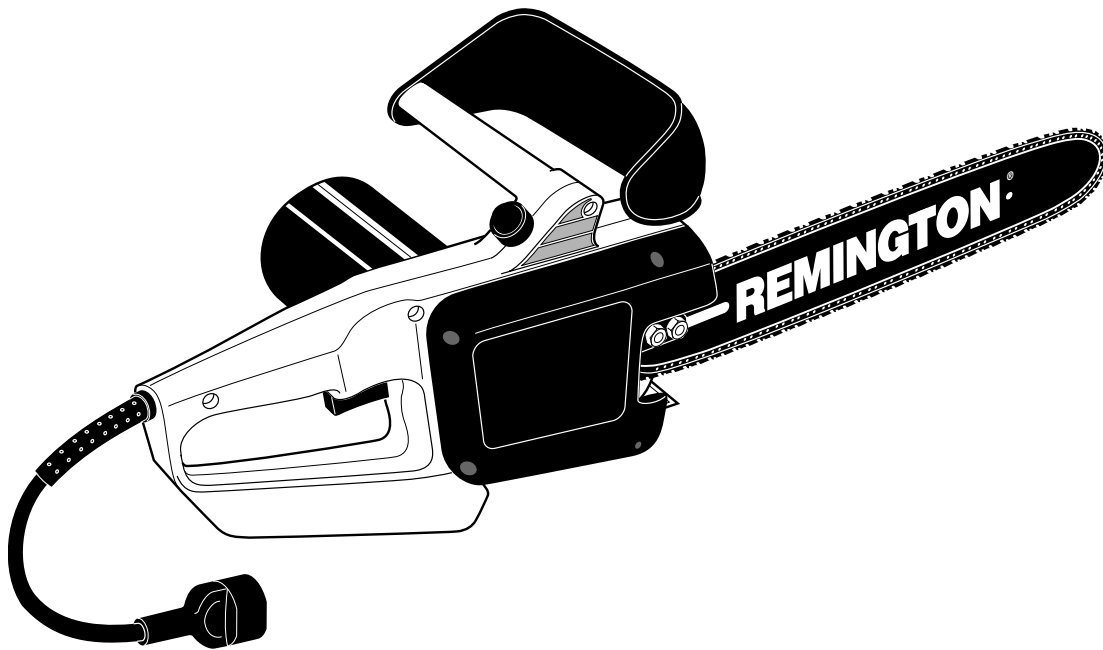

MODELS

LNT-2: 076728K, 099178H, 100089-06, 100089-08, & 107709-01

EL-7: 075762J, 098031J, 099039J, 100089-04, 100089-05,
100089-07, & 107714-02

Pole Saw: 104316-04 (8"), 106890-01(10")

Pole Saw Assembly: 104317 (8"), 106821 (10")

IMPORTANT: Read and understand this manual before assembling or operating this chain saw. Improper use of saw can cause severe injury. Keep this manual for future reference.



REMINGTON®

ELECTRIC CHAIN SAW

SAFETY WARNINGS

Make certain you read and understand all Safety Warnings on pages 2 and 3. Improper use of this chain saw can cause severe injury or death from fire, electrical shock, body contact with moving chain, or falling wood.

BEFORE OPERATING SAW

1. Read and understand this owner's manual before operating chain saw.
2. Watch what you are doing. Use common sense. Do not operate saw when you are tired.
3. Use chain saw for cutting wood only. Do not use chain saw for purpose not intended. Do not use for cutting plastic, masonry, etc.
4. Only well-instructed adults should operate chain saw. Never allow children to operate chain saw.
5. Use only electrical voltage noted on model plate of chain saw.
6. Use only extension cords marked for outdoor use. See page 8 for extension cord requirements.
7. Do not operate chain saw
 - while under the influence of alcohol, medication, or drugs
 - in rain or in damp or wet areas
 - where highly flammable liquids or gases are present
 - if saw is damaged, adjusted wrong, or not fully and securely assembled
 - if trigger does not turn saw on and off. Chain must stop moving when you release trigger. Have faulty switch replaced by authorized service center.
 - while in a hurry
 - while in tree or on a ladder unless trained to do so
8. Wear snug-fitting clothes when operating chain saw. Do not wear loose clothing or jewelry. They can get caught in moving saw chain.
9. Wear the following safety gear when operating chain saw.
 - heavy-duty gloves (wear rubber gloves when working outdoors)
 - steel-toed safety footwear with non-skid soles

- eye protection such as safety glasses, goggles, or face screen
 - safety hard hat
 - ear muffers or ear plugs
 - hair covering to contain long hair
 - face or dust mask (if working in dusty areas)
10. Before cutting, always provide the following:
 - clear work area
 - secure footing
 - planned retreat path from falling tree
 11. Inspect tree before cutting down. Make sure there are no dead limbs or branches that may fall on you.
 12. To reduce the risk of electric shock, this saw has a polarized plug (one blade is wider than the other). This plug will fit in a polarized outlet only one way. If the plug does not fit fully in the outlet of your extension cord, reverse the plug. If it still does not fit, a polarized extension cord will be necessary. Do not change the plug in any way.

WHILE OPERATING SAW

1. Stay alert. Use common sense while operating chain saw.
2. Keep work area clean. Cluttered areas invite injuries.
3. Be aware of extension cord while operating chain saw. Be careful not to trip over cord. Keep cord away from chain and operator at all times.
4. Keep children, animals, and bystanders away from chain saw and extension cord. Only chain saw user should be in work area.
5. Do not cut down a tree unless you are trained or have expert help.
6. If two or more persons perform bucking and felling operations at the same time, provide plenty of distance between operations. Provide distance of at least twice the height of tree being felled.
7. Secure wood you are cutting by using clamps or chocks.
8. Grip chain saw firmly with both hands. Never operate chain saw with one hand. Never use hand guard as handle.
9. Keep finger off trigger until ready to make cut.
10. Before starting chain saw, make sure chain is not touching anything.
11. To guard against electrical shock, avoid

- body contact with grounded objects such as pipes, fences, and metal posts.
12. Keep all parts of body away from chain when saw is running.
 13. Do not force chain saw while cutting. Apply light pressure. It will do the job better and safer at the rate for which it was intended.
 14. Cut small brush and saplings with extreme care. Slender material may catch in chain and be whipped toward you. This could also pull you off balance.
 15. When cutting limb or tree trunk that is under tension, use extreme caution. Be alert for wood springing back. When wood tension is released, limb could spring back and strike operator causing severe injury or death.
 16. Carry chain saw from one place to another
 - with saw stopped and unplugged
 - by holding front handle (never use hand guard as handle)
 - with finger off trigger
 - with guide bar and chain to rear

 **WARNING: This product contains chemicals known to the State of California to cause cancer or birth defects, or other reproductive harm.**

 **WARNING: Some dust created by power sanding, sawing, grinding, drilling, and other construction activities contains chemicals known (to the state of California) to cause cancer, birth defects, or other reproductive harm. Some examples of these chemicals are:**

- lead from lead-based paints
- crystalline silica from bricks and cement and other masonry products
- arsenic and chromium from chemically-treated lumber

Your risk from these exposures varies, depending on how often you do this type of work. To reduce your exposure to these chemicals: work in a well ventilated area, and work with approved safety equipment, such as those dust masks that are specially designed to filter out microscopic particles.

SAFETY WARNINGS

KICKBACK

⚠ WARNING: Kickback may occur when the nose or tip of the guide bar touches an object, or when the wood closes in and pinches the saw chain in the cut. Tip contact in some cases may cause a lightning fast reverse reaction, kicking the guide bar up and back towards the operator. Pinching the saw chain along the top of the guide bar may push the guide bar rapidly back towards the operator. Either of these reactions may cause you to lose control of the saw which could result in serious injury to user.

Kickback Safety Devices On This Saw

This saw has a low-kickback chain and reduced kickback guide bar. Both items reduce the chance of kickback. Kickback can still occur with this saw.

Properly install front hand guard. This item can reduce injuries from kickback. Follow assembly instructions on page 6. Do not remove front hand guard. Do not replace front hand guard with substitute.

The following steps will reduce the risk of kickback.

- Use both hands to grip saw while saw is running. Use firm grip. Thumbs and fingers must wrap around saw handles.
- Keep all safety items in place on saw. Make sure they work properly.
- Do not overreach or cut above shoulder height.
- Keep solid footing and balance at all times
- Stand slightly to left side of saw. This keeps your body from being in direct line with chain.
- Do not let guide bar nose touch anything when chain is moving (see Figure 1).

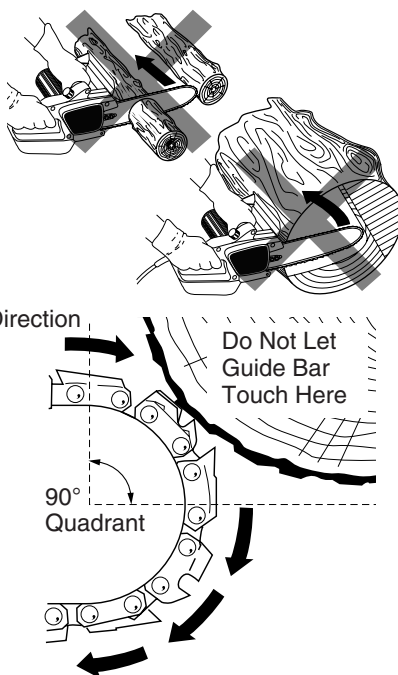

Figure 1 - Kickback Hazard Example: Do Not Let Nose of Guide Bar Touch Object While Chain is Moving

- Never try cutting through two logs at same time. Only cut one log at a time.
- Do not bury guide bar nose or try plunge cut (boring into wood using guide bar nose).
- Watch for shifting of wood or other forces that may pinch chain.
- Use extreme caution when reentering a previous cut.
- Use low-kickback chain and guide bar supplied with this chain saw. Only replace these parts with chains and guide bars listed in this manual.
- Never use dull or loose chain. Keep chain sharp with proper tension.
- Do not hand sharpen chain on automatic chain sharpening (Fast Sharp) models.

Saw Maintenance and Kickback Safety

Follow maintenance instructions in this manual. Proper cleaning of saw and chain and guide bar maintenance can reduce chances of kickback. Inspect and maintain saw after each use. This will increase the service life of your saw. **Note:** Even with proper sharpening, risk of kickback can increase with each sharpening.

MAINTENANCE AND STORAGE OF CHAIN SAW

1. Unplug chain saw from power source
 - when not in use
 - before moving from one place to another
 - before servicing
 - before changing accessories or attachments, such as saw chain and guard
2. Inspect chain saw before and after each use. Check saw closely if guard or other part has been damaged. Check for any damage that may affect operator safety or operation of saw. Check for alignment or binding of moving parts. Check for broken or damaged parts. Do not use chain saw if damage affects safety or operation. Have damage repaired by authorized service center.
3. Maintain chain saw with care.
 - Never expose saw to rain.
 - Keep chain sharp, clean, and lubricated for better and safer performance.
 - Follow steps outlined in this manual to sharpen chain.
 - Keep handles dry, clean, and free of oil and grease.
 - Keep all screws and nuts tight.
 - Inspect power cord often. If damaged, have repaired by authorized service center.
 - Never carry chain saw by power cord.
 - Never yank power cord to unplug it.
 - Keep power cord from heat, oil, and sharp edges.
 - Inspect extension cords often and replace if damaged.
4. When servicing, use only identical replacement parts.
5. When not in use, always store chain saw
 - in a high or locked place, out of children's reach
 - in a dry place
 - in a carrying case or with scabbard over guide bar

Keep this manual for reference. It is your guide to safe and proper operation of this chain saw.

REMINGTON®

ELECTRIC CHAIN SAW

CHAIN SAW NAMES AND TERMS

Bucking Process of cutting a felled tree or log into lengths.

Felling Process of cutting down a tree.

Felling Cut Final cut when felling a tree. Make this cut on opposite side of tree from notching cut.

Front Handle Located at front of saw body.

Front Hand Guard Shield between front handle and guide bar. Protects left hand while using saw.

Guide Bar Metal bar that extends from saw body. The guide bar supports and guides chain.

Guide Bar Nose Tip or end of guide bar.

Kickback Quick backward and upward motion of guide bar. Kickback may occur when tip of guide bar touches an object while chain is moving. The guide bar will kick up and back towards operator.

Limbing Process of cutting limb(s) from a felled tree.

Low-Kickback Chain Chain that reduces chance of kickback as required by ANS B175.1.

Normal Cutting Position Stance used while making bucking and felling cuts.

Notching Cut Notch cut in tree that directs fall of tree.

Oiler Control System for oiling guide bar and chain.

Power Head Chain saw without chain and guide bar. Also known as saw body.

Pushback (Kickback, Pinch) Rapid pushback of chain saw. Pushback may occur if chain along top of guide bar is pinched, caught, or contacts a foreign object.

Rear Handle Handle located at rear of saw body.

Reduced Kickback Guide Bar Guide bar that reduces chance of kickback.

Replacement Chain Chain that complies with ANS B175.1 when used with a specific saw. It may not meet ANS requirements when used with other saws.

Saw Chain (Chain) Loop of chain having cutting teeth for cutting wood. The motor drives chain. The guide bar supports chain.

Spiked Bumper (Spike) Pointed teeth at front of saw body beside guide bar. Keep spiked bumper in contact with wood when felling or bucking. It helps maintain position of saw while cutting.

Sprocket Toothed wheel that drives chain.

Switch Device that completes or interrupts electrical circuit to motor of saw.

Switch Linkage This device connects switch to trigger. It moves switch when you squeeze trigger.

Switch Lockout Device that reduces accidental starting of saw.

Trigger Device that turns saw on and off. Squeezing trigger turns saw on.

Releasing trigger turns saw off.

Trimming (Pruning) Process of cutting limb(s) from a living tree.

Undercut An upward cut from underside of log or limb. This is done while in normal cutting position and cutting with top of guide bar.

OWNER'S MANUAL

PRODUCT IDENTIFICATION

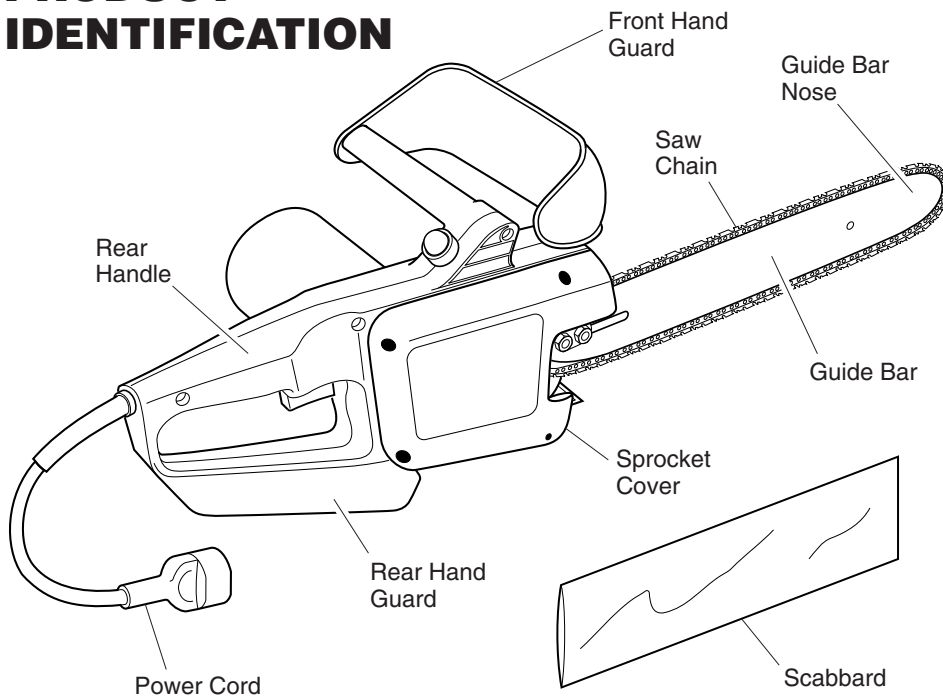

UNPACKING

1. Remove all items from carton.
2. Check all items for any shipping damage. If you find any damage or if any parts are missing, promptly inform dealer where you bought chain saw.

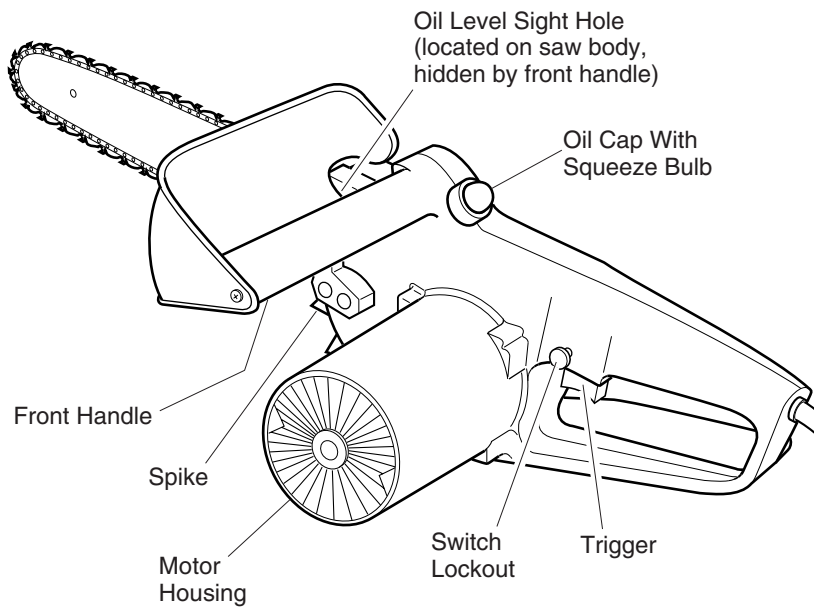

Figure 2 - Electric Chain Saw

REMINGTON®

ELECTRIC CHAIN SAW

ASSEMBLY

Note: Some models are pre assembled. Assembly is not needed on these models.

See *Saw Chain Tension Adjustment*, page 7.

⚠ WARNING: Cutting edges on chain are sharp. Use protective gloves when handling chain.

IMPORTANT: Do not clamp chain saw in vise during assembly.

The plastic hardware bag should include:

- two guide bar bolts
- two guide bar nuts
- one Phillips-head tapping screw
- automatic chain sharpener (Fast Sharp models only)

1. Lay chain out flat.
2. Install front hand guard onto saw body. Do this by pressing two mounting stand-outs on hand guard into hex-shaped holes in saw body (see Figure 3).
3. Insert tapping screw through hand guard and into saw handle. Tighten screw firmly.
4. Turn adjusting screw counterclockwise (see Figure 4). Continue to turn adjusting screw until adjusting block is to rear of adjusting plate.
5. Install guide bar onto saw body. Place rear of guide bar between adjusting plate and sprocket support.

IMPORTANT: Make sure to insert adjusting block into oval adjusting hole on guide bar.

6. Line up holes on sprocket support with center slot on guide bar and holes in saw body.
7. Insert guide bar bolts through front hand guard, saw body, center slot of guide bar, and sprocket support. Attach guide bar nuts to guide bar bolts.

IMPORTANT: Tighten guide bar nuts finger tight only. Make sure adjusting block is in oval adjusting hole on guide bar.

8. Place chain around drive sprocket, then along top groove of guide bar and around guide bar nose. *Note:* Make sure cutting edges of chain are facing the right direction. Position chain so cutting edges on top of guide bar face guide bar nose (see Figure 3).

⚠ CAUTION: Do not place chain on saw backwards. If chain is backwards, saw will vibrate badly and will not cut.

9. Adjust saw chain tension. Follow steps under *Saw Chain Tension Adjustment*, page 7.

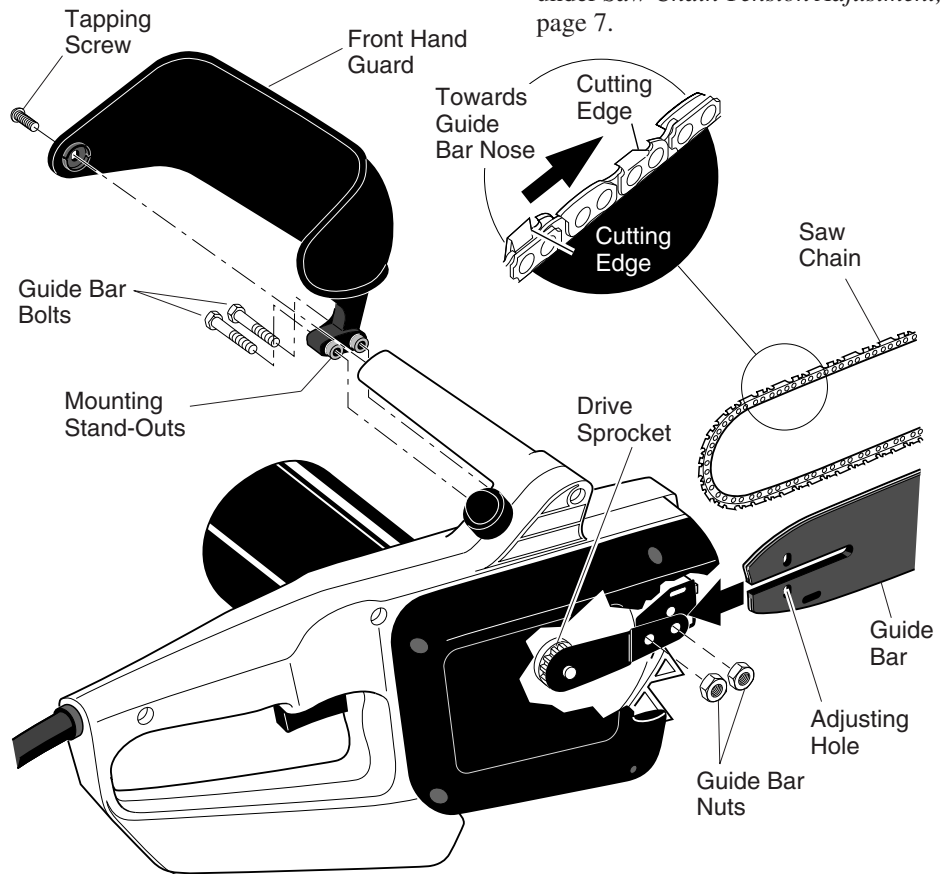

Figure 3 - Assembling Guide Bar, Chain, and Hand Guard

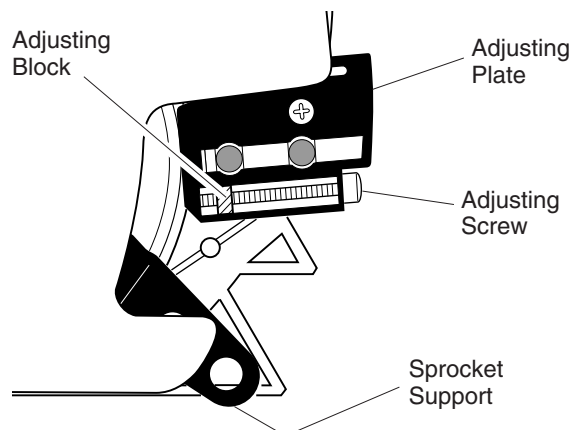

Figure 4 - Part Locations For Assembling Guide Bar

SAW CHAIN TENSION ADJUSTMENT

⚠ WARNING: Unplug chain saw from power source before adjusting saw chain tension.

⚠ WARNING: Cutting edges on chain are sharp. Use protective gloves when handling chain.

⚠ WARNING: Maintain proper chain tension always. A loose chain will increase the risk of kickback. A loose chain may jump out of guide bar groove. This may injure operator and damage chain. A loose chain will cause chain, guide bar, and sprocket to wear rapidly.

Note: For pre-assembled models, the saw chain tension is properly set at factory. A new chain will stretch. Check new chain after first few minutes of operation. Allow chain to cool down. Follow steps below to readjust saw chain tension.

1. Before adjusting chain, make sure guide bar nuts are only finger tight (see Figure 3, page 6). Also make sure adjusting block is in oval adjusting hole on guide bar (see Figures 3 and 4, page 6).
2. Turn adjusting screw clockwise until all slack is out of chain (see Figure 5). *Note:* There should be no gap between side links of chain and bottom of guide bar (see Figure 6).
3. Wearing protective gloves, move chain around guide bar. Chain should move freely. If chain does not move freely, loosen chain by turning adjusting screw counterclockwise.

4. After chain tension is correct, tighten guide bar nuts firmly. If not, guide bar will move and loosen chain tension. This will increase the risk of kickback. This can also damage saw. *Note:* A new chain will stretch. Check new chain after first few minutes of operation. Allow chain to cool down. Readjust chain tension.

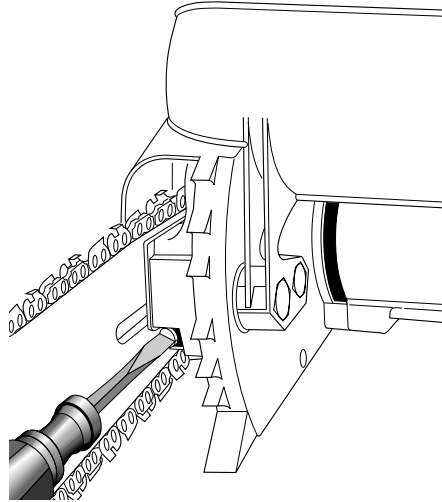

Figure 5 - Turning Adjusting Screw

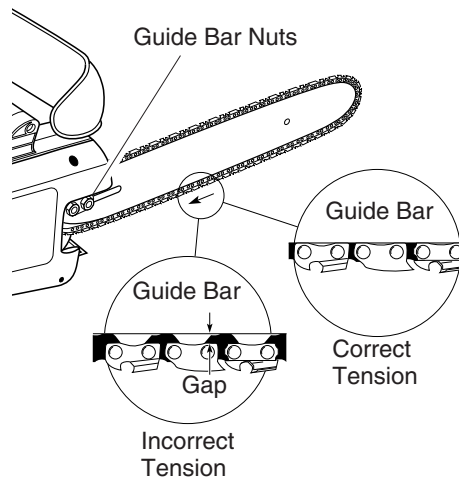

Figure 6 - Saw Chain Adjustment

FILLING OIL TANK

1. Remove oil cap.
2. Fill oil tank with SAE #30 motor oil. *Note:* For temperatures below 30°F, use SAE #10 oil. For temperatures above 75°F, use SAE #40 oil.
3. Replace oil cap at once. Tighten oil cap firmly for good seal. This will avoid oil seepage from tank.
4. Wipe off excess oil.

Note: It is normal for oil to seep when saw is not in use. Empty oil tank after each use to prevent seepage.

REMINGTON®

ELECTRIC CHAIN SAW

OPERATING CHAIN SAW

⚠ WARNING: Read and understand this owner's manual before operating this saw. Make certain you read and understand all *Safety Warnings*, pages 2 and 3. Improper use of this chain saw can cause severe injury or death from fire, electrical shock, or body contact with moving chain, or falling wood.

EXTENSION CORDS

Use proper extension cords with this saw. Use only extension cords marked for outdoor use. The cord must be marked with suffix W or W-A following the cord type designation. *Example:* SJTW-A or SJTW.

Use proper sized cord with this saw. Cord must be heavy enough to carry current needed. An undersized cord will cause voltage drop at saw. Saw will lose power and overheat. Follow cord size requirements listed below.

Cord Length	AWG Cord Size
25 feet	16 AWG
50 feet	16 AWG
100 feet	16 AWG
150 feet	14 AWG

Models LNT-2: 076728K, 099178H, 100089-06, & 100089-08; **Pole Saw Assy** 104317 & 106821; **Pole Saw** 104316-04 (8") & 106890 (10")

Cord Length	AWG Cord Size
25 feet	16 AWG
50 feet	16 AWG
100 feet	14 AWG
150 feet	12 AWG

Models EL-7: 075762J, 098013J, 099039J, 100089-04, 100089-05, & 100089-07

Keep cord away from cutting area. Make sure cord does not catch on branches or logs during cutting. Inspect cords often. Replace damaged cords.

The extension cord may come undone from the power cord during use. To avoid this, make a knot with the two cords as shown in Figure 7 below.

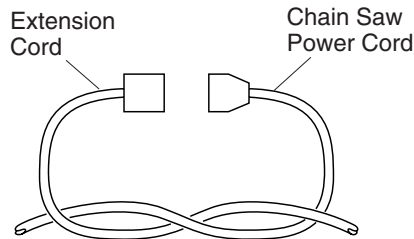

Figure 7 - Tying Extension Cord and Power Cord in Knot

OILING CHAIN

Always check oil level before using saw. To oil chain, press squeeze bulb on oil cap. Do not attempt to operate the oiler while cutting with the saw. Oil will feed onto guide bar and chain. Press squeeze bulb on oil cap at least once before each cut. Check oil level often by looking at oil sight level hole. Oil sight level hole is on left side of saw, between front handle and front hand guard.

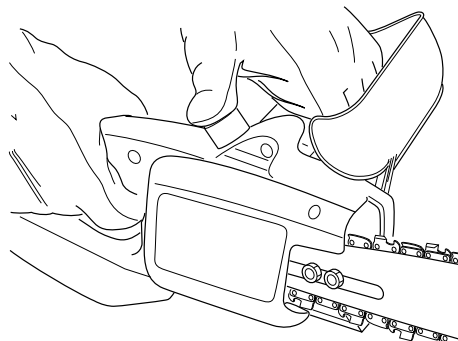

Figure 8 - Pressing Squeeze Bulb on Oil Cap to Oil Chain

CUTTING WITH THE CHAIN SAW

1. Connect saw to extension cord. Connect extension cord to power supply.
2. Make sure section of log to be cut is not laying on ground. This will keep chain from touching ground as it cuts through log. Touching ground with moving chain will dull chain.
3. Use both hands to grip saw. Always use left hand to grip front handle and right hand to grip rear handle. Use firm grip. Thumbs and fingers must wrap around saw handles (see Figure 9).
4. Make sure your footing is firm. Keep feet apart. Divide your weight evenly on both feet.
5. When ready to make a cut, press in switch lockout with right thumb and squeeze trigger (see Figure 9). This will turn saw on. Releasing trigger will turn saw off. Make sure saw is running at full speed before starting a cut.
6. When starting a cut, place moving chain against wood. Hold saw firmly in place to avoid possible bouncing or skating (sideways movement) of saw.
7. Guide saw using light pressure. Do not force saw. The motor will overload and can burn out. It will do the job better and safer at the rate for which it was intended.
8. Remove saw from a cut with saw running at full speed. Stop saw by releasing trigger. Make sure chain has stopped before setting saw down.
9. Practice until you can maintain a steady, even cutting rate.

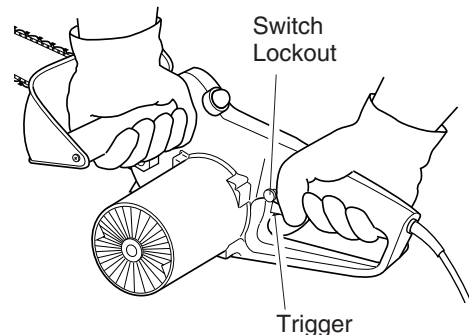

Figure 9 - Switch Lockout and Trigger Location

OPERATING CHAIN SAW

Continued

FELLING A TREE (Cutting Down a Tree)

⚠ WARNING:

- Avoid kickback. Kickback can result in severe injury or death. See *Kickback*, page 3 to avoid risk of kickback.
- Do not fell a tree without ample skill or expert help.
- Keep children, animals, and bystanders away from area when felling a tree.
- If two or more persons perform bucking and felling operations

⚠ **WARNING:** When felling a tree, be aware of your surroundings. Do not endanger any person, strike utility lines, or cause property damage. If tree strikes utility lines, contact utility company at once.

Felling is the process of cutting down a tree. Make sure your footing is firm. Keep feet apart. Divide your weight evenly on both feet. Follow directions below to fell a tree.

Before Felling a Tree

1. Before felling, inspect tree. Make sure there are no dead limbs or branches that may fall on you. Study natural lean of tree, location of larger branches, and wind direction. This will help you judge which way tree will fall.
2. Clear work area around tree.
3. Plan and clear a retreat path before felling. Make retreat path opposite to planned direction of fall of tree and at 45° angle (see Figure 10).
4. Remove dirt, stones, loose bark, nails, staples, and wire from tree where you will make felling cuts.
5. Stay on uphill side when felling tree. Tree could roll or slide downhill after falling.

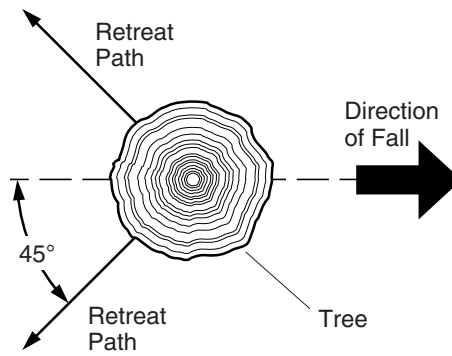

Figure 10 - Retreat Path From Tree

Felling Procedure

A) Felling Notch

A properly placed felling notch will determine direction tree will fall. Place felling notch on side of tree in direction you want tree to fall (see Figure 11). Follow directions below to create a felling notch.

1. Make lower notch cut as close to ground as possible. Hold saw so guide bar is horizontal. Cut 1/3 the diameter of tree trunk (see Figure 11). *Note:* Always make this horizontal lower notch cut first. If you make this cut second, tree can pinch chain or guide bar.
2. Start upper notch cut the same distance above first cut as first cut is deep.

Example: If lower notch cut is eight inches deep, start upper notch cut eight inches above it. Cut downward at 45° angle. The upper notch cut should meet end of lower notch cut (see Figure 11).

3. Remove tree trunk wedge created by notching cuts.

B) Felling Cut

1. Make felling cut two inches higher than lower notch cut and on opposite side of tree (see Figure 11). Keep felling cut parallel to lower notch cut.
2. Cut towards notch.

⚠ **WARNING:** Do not cut all the way through tree. Leave about two inches of tree diameter uncut directly behind felling notch (see Figure 11). This uncut portion acts as a hinge. The hinge helps keep tree from twisting and falling in wrong direction.

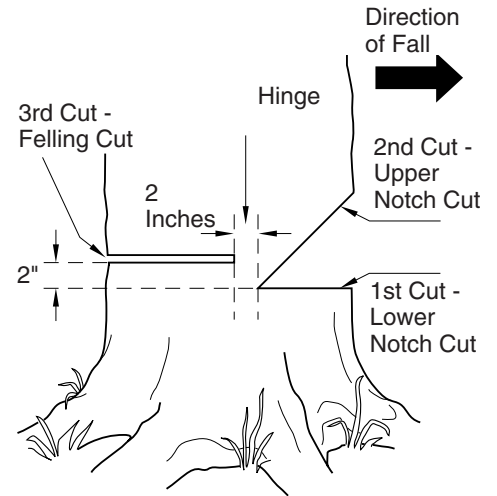

Figure 11 - Felling A Tree

3. As felling cut nears hinge, tree should begin to fall. *Note:* If needed, drive wedges into felling cut to control direction of fall. If tree settles back and pinches chain, drive wedges into felling cut to remove saw. Only use wedges made of wood, plastic, or aluminum. Never use wedge made of steel. This could cause kickback and damage to chain.
4. When tree begins to fall, quickly
 - remove saw from felling cut
 - release trigger to turn saw off
 - put saw down
 - exit area using retreat path

⚠ **WARNING:** Be alert for falling overhead limbs. Watch your footing while exiting area.

REMINGTON®

ELECTRIC CHAIN SAW

OPERATING CHAIN SAW

Continued

LIMBING A TREE

⚠ WARNING: Avoid kickback. Kickback can result in severe injury or death. See *Kickback*, page 3 to avoid risk of kickback.

⚠ WARNING: When cutting limb that is under tension, use extreme caution. Be alert for wood springing back. When wood tension is released, limb could spring back and strike operator causing severe injury or death.

Limbing is removing branches from a fallen tree. Make sure your footing is firm. Keep feet apart. Divide your weight evenly on both feet. Do not remove larger limbs under tree that support log off ground. Remove each limb with one cut (see Figure 12). Clear cut limbs from work area often. This will help maintain a safe work area.

Make sure you start your cut where limb will not pinch saw during cutting. To avoid pinching, start cut on freely hanging limbs from above limb. Start cut on limbs under tension from under limb. If pinch occurs, turn saw off, lift limb, and remove saw.

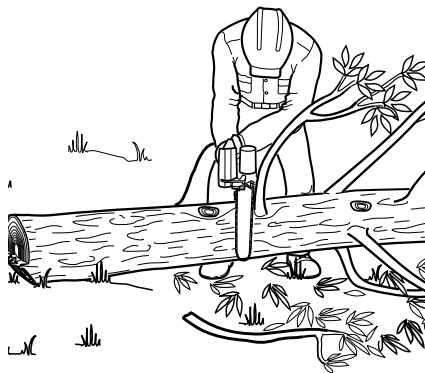

Figure 12 - Limbing A Tree

BUCKING A LOG

⚠ WARNING: Avoid kickback. Kickback can result in severe injury or death. See *Kickback*, page 3 to avoid risk of kickback.

- ⚠ WARNING:**
- If on slope, make sure log will not roll down hill. Secure log by using wooden stakes. Drive wooden stakes into ground on downhill side of log. Stand on uphill side of log while cutting. Log may roll after cutting.
 - Never try cutting through two logs at same time. This could increase the risk of kickback.
 - While cutting log, never hold log with your hand, leg, or foot.
 - While cutting log, never allow another person to hold log.
 - Turn off and unplug saw before moving from one place to another.

Bucking a log is cutting a log into sections. Make sure your footing is firm. Keep feet apart. Divide your weight evenly on both feet. When possible, raise log or section off ground. Do this by using limbs, logs, chocks, etc.

When cutting through log, maintain control by reducing cutting pressure near end of cut. Do not relax your grip on chain saw handles. Do not let moving chain touch ground. Ground will dull moving chain. After cutting through log, release trigger to turn saw off before moving saw.

Follow directions below to buck a log.

Entire Length Of Log On Ground

Cut log from top (see Figure 13).

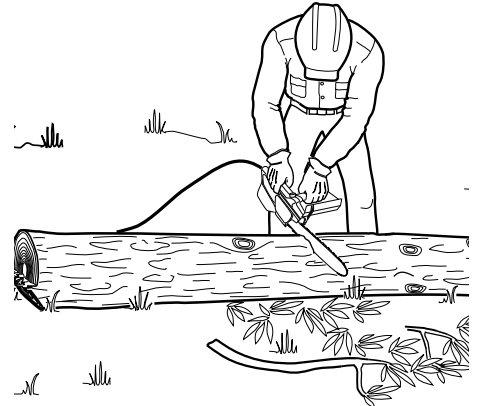

Figure 13 - Bucking Log With Entire Length On Ground

Log Supported On One End

1. Make first cut on underside of log (see Figure 14). Use top of guide bar to make this cut. Cut 1/3 through diameter of log. This cut will keep section from splintering when cut.
2. Make second cut directly above first cut. Cut down to meet first cut. This cut will keep log from pinching guide bar and chain.

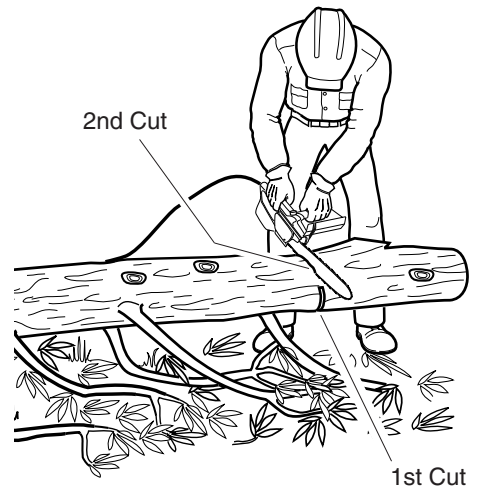

Figure 14 - Bucking Log When Log Is Supported On One End

OPERATING CHAIN SAW

Continued

Log Supported On Both Ends

1. Make first cut from above log (see Figure 15). Cut 1/3 through diameter of log. This cut will keep section from splintering when cut.
2. Make second cut on underside of log, directly under first cut. Use top of guide bar to make this cut. Cut up to meet first cut. This will keep log from pinching guide bar and chain.

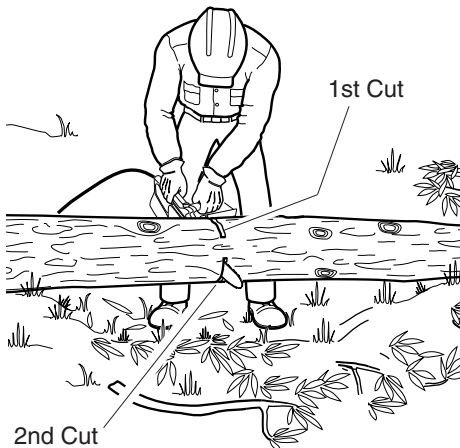

Figure 15 - Bucking Log When Log Is Supported On Both Ends

TRIMMING A TREE (Pruning)

⚠ WARNING: Avoid kickback. Kickback can result in severe injury or death. See *Kickback*, page 3 to avoid risk of kickback.

⚠ WARNING: Do not operate chain saw while

- in a tree
- on a ladder or any other unstable surface
- in any awkward position

You may lose control of saw causing severe injury.

⚠ WARNING: Do not cut limbs higher than your shoulders.

⚠ CAUTION: Seek professional help if facing conditions beyond your ability.

Trimming a tree is the process of cutting limbs from a living tree. Make sure your footing is firm. Keep feet apart. Divide your weight evenly on both feet. Follow directions below to trim a tree.

1. Make first cut six inches from tree trunk on underside of limb. Use top of guide bar to make this cut. Cut 1/3 through diameter of limb (see Figure 16).
2. Move two to four inches farther out on limb. Make second cut from above limb. Continue cut until you cut limb off.
3. Make third cut as close to tree trunk as possible on underside of limb stub. Use top of guide bar to make this cut. Cut 1/3 through diameter of stub.
4. Make fourth cut directly above third cut. Cut down to meet third cut. This will remove limb stub.

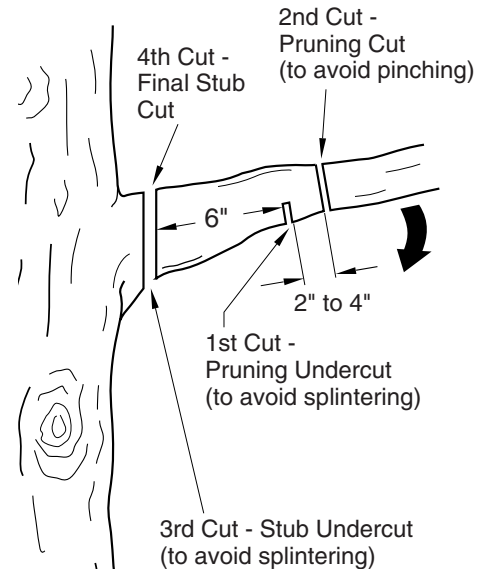

Figure 16 - Cutting A Limb

REMINGTON®

ELECTRIC CHAIN SAW

CLEANING AND MAINTENANCE

NOTICE: Below are instructions for servicing your chain saw. Any servicing not mentioned below should be done by an authorized service center.

CLEANING SAW BODY

⚠ WARNING: Unplug chain saw from power source before servicing. Severe injury or death could occur from electrical shock or body contact with moving chain.

⚠ WARNING: Cutting edges on chain are sharp. Use protective gloves when handling chain.

⚠ WARNING: When cleaning saw body,

- do not submerge saw in any liquids
- do not use products that contain ammonia, chlorine, or abrasives
- do not use chlorinated cleaning solvents, carbon tetrachloride, kerosene, or gasoline

Keep saw body clean. Use a soft cloth dampened with a mild soap and water mixture. Wipe saw body to clean.

CARE OF GUIDE BAR

Uneven bar wear causes most guide bar problems. Incorrect sharpening of chain cutter and depth gauge settings often cause this. When bar wears unevenly, it widens guide bar groove (see Figure 17). This causes chain clatter and rivet popping. Saw will not cut straight. Replace guide bar if this occurs.

Inspect guide bar before sharpening chain. A worn or damaged guide bar is unsafe. A worn or damaged guide bar will damage chain. It will also make cutting harder.

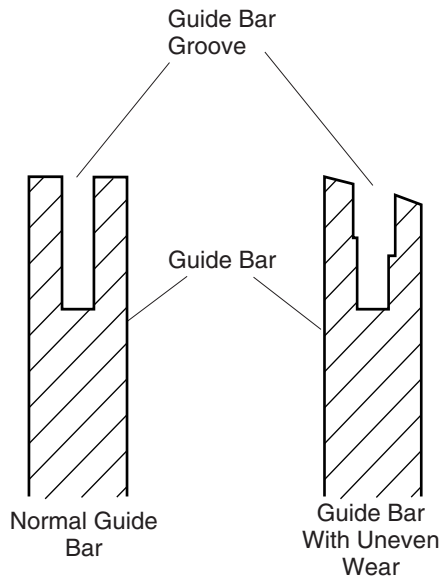

Figure 17 - Guide Bar Cross Section Showing Uneven Bar Wear

Normal Guide Bar Maintenance

1. Remove guide bar from chain saw.
2. Remove sawdust from guide bar groove periodically. Use putty knife or wire.
3. Clean oil slots after each day of use.
4. Remove burrs from sides of guide bar. Use flat file to make side edges square.

Replace guide bar when

- bar is bent or cracked
- inside groove of bar is badly worn

Note: When replacing guide bar, see *Replacement Parts and Accessories*, page 19, for proper bar.

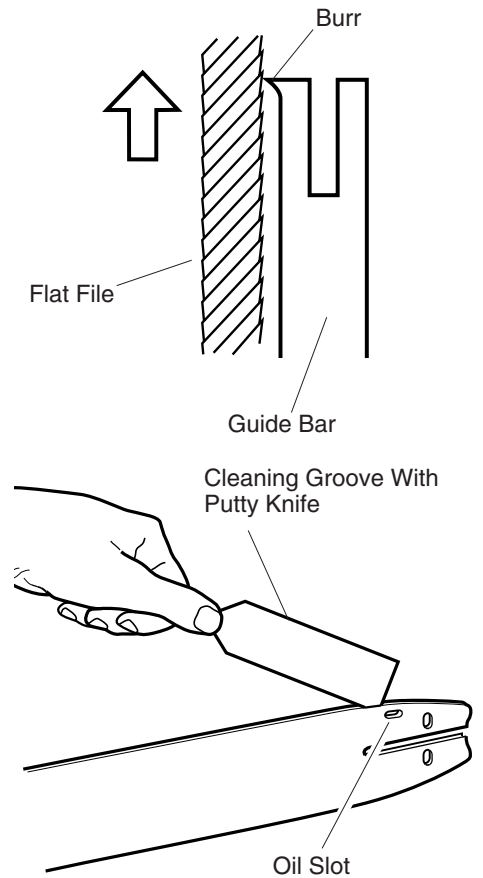

Figure 18 - Guide Bar Maintenance

CLEANING AND MAINTENANCE

Continued

SHARPENING SAW CHAIN

⚠ WARNING: Unplug chain saw from power source before servicing. Severe injury or death could occur from electrical shock or body contact with moving chain.

⚠ WARNING: Cutting edges on chain are sharp. Use protective gloves when handling chain.

Keep chain sharp. Your saw will cut faster and more safely. A dull chain will cause undue sprocket, guide bar, chain, and motor wear. If you must force chain into wood and cutting creates only sawdust with few large chips, chain is dull.

Items Needed to Sharpen Chain

Purchase these items from your local dealer, hardware store, or chain saw supplies outlet.

- 5/32" round file
- Depth gauge tool
- File guide
- Vise
- Medium sized flat file

Sharpening Cutters

Use file guide for 30° filing.

1. Adjust chain for proper tension (see *Saw Chain Tension Adjustment*, page 7).
2. Clamp guide bar in vise to hold saw steady. *Note:* Do not clamp chain.
3. Press 5/32" round file (attached to file guide) into groove between top plate and depth gauge on chain. File guide should rest on both top plate and depth gauge (see Figures 19 and 20). *Note:* File at midpoint of guide bar.

4. Hold file guide level. Make sure 30° mark on file guide is parallel to center of guide bar (see Figure 19). This will insure that you file cutters at 30° angle.
5. File from inside towards outside of cutter until sharp. Only file in this one direction (see Figure 19). *Note:* Two or three strokes with file should sharpen cutter.
6. After each cutter is sharpened, move chain forward to sharpen next cutter. File all cutters on one side of chain.
7. Move to other side of chain and repeat process.

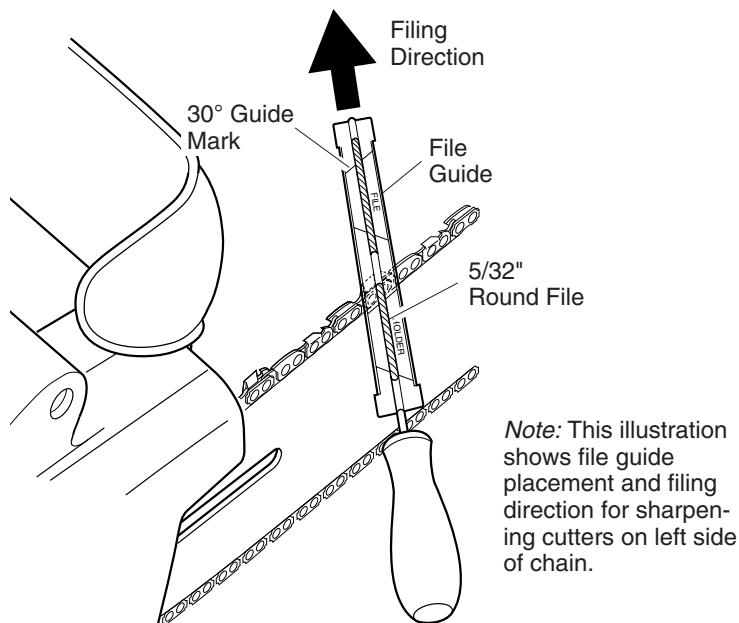

Note: This illustration shows file guide placement and filing direction for sharpening cutters on left side of chain.

Figure 19 - File and File Guide Placement On Chain

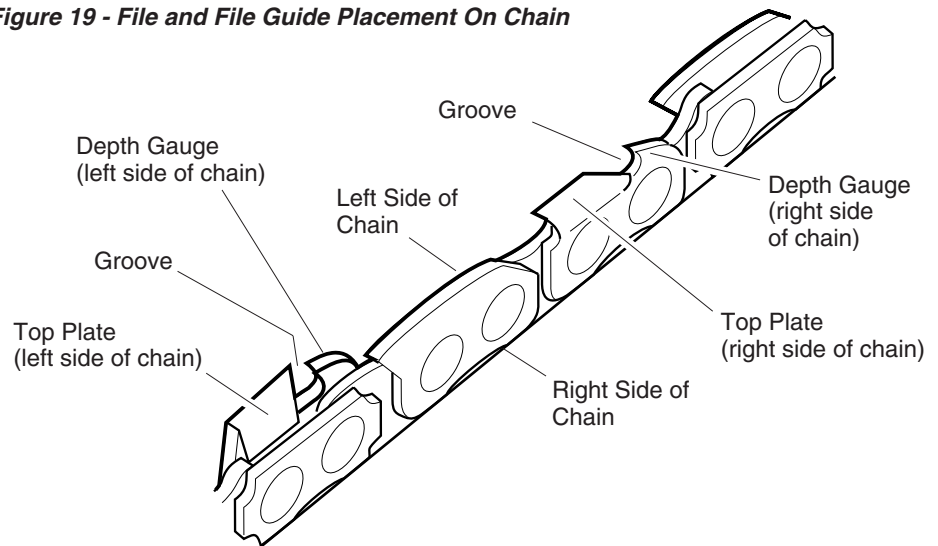

Figure 20 - Chain Part Locations

Continued

REMINGTON®

ELECTRIC CHAIN SAW

CLEANING AND MAINTENANCE

Continued

Filing Cutter Depth Gauges

The cutter depth gauge clearance is reduced as cutters are sharpened. After every second or third sharpening, reset cutter depth gauges.

1. Place depth gauge tool (.025") firmly across top of two cutters. Make sure depth gauge enters slot in depth gauge tool (see Figure 21).
2. Use medium flat file. File depth gauge level with depth gauge tool.
3. Remove depth gauge tool. With flat file, round off front corner of cutter depth gauge (see Figure 22).

After several hand filings, have authorized service center or sharpening service machine sharpen chain. This will insure even filing.

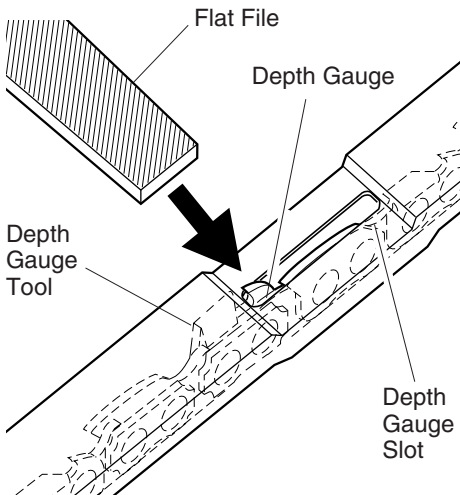

Figure 21 - Depth Gauge Tool On Chain

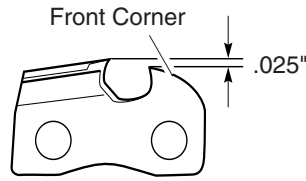

Figure 22 - Round Off Front Corner Of Depth Gauge

REPLACING SAW CHAIN

Replace chain when cutters are too worn to sharpen or when chain breaks. Only use replacement chain noted in this manual. Always include new drive sprocket when replacing chain. This will maintain proper driving of chain. **Note:** For proper chain and drive sprocket, see *Replacement Parts and Accessories*, page 19.

STORAGE

If storing saw for more than 30 days, follow steps below.

1. Drain oil tank.
2. Remove and clean guide bar and chain. Clean guide bar and chain by soaking in petroleum based solvent or mild soap and water mixture.
3. Dry guide bar and chain.
4. Place chain in container filled with oil. This will prevent rust.
5. Wipe a thin coating of oil over surface of guide bar.
6. Wipe off outside of saw body. Do this with soft cloth dampened with a mild soap and water mixture.
7. Store chain saw
 - in a high or locked place, out of children's reach
 - in a dry place
 - in a carrying case or with scabbard over guide bar

TECHNICAL SERVICE

You may have further questions about assembling, operating, or maintaining this saw. If so, contact our Technical Service Department at 1-800-858-8501.

You can also visit our technical service web site at www.desatech.com.

SERVICE PUBLICATIONS

You can receive an illustrated parts list free of charge. Send a self-addressed stamped envelope to address on back page of this manual.

When writing, include model number and serial number of saw. You will find these numbers on saw motor housing decal.

OWNER'S MANUAL

TROUBLESHOOTING

Note: For additional help, visit our technical service web site at www.desatech.com.

⚠ WARNING: Unplug chain saw from power source before servicing. Severe injury or death could occur from electrical shock or body contact with moving chain.

OBSERVED FAULT	POSSIBLE CAUSE	REMEDY
Saw runs, but does not cut	Chain assembled backwards on guide bar	See <i>Assembly</i> , page 6
Saw does not cut unless heavily forced. Cutting produces only sawdust with few large chips	Chain is dull	See <i>Sharpening Saw Chain</i> , page 13
Saw runs slow. Saw stalls easily	Low power supply voltage	Extension cord wire size too small. See <i>Extension Cords</i> , page 8
Motor of saw does not run when you squeeze trigger	<ol style="list-style-type: none">1. Switch lockout not pressed in to release trigger2. Extension cord connections loose3. Open line fuse or circuit breaker4. Bad motor brushes5. Open wiring circuit on saw	<ol style="list-style-type: none">1. Press in switch lockout before squeezing trigger2. Check cord connections3. Check line fuse or circuit breaker4. See authorized service center5. See authorized service center
Motor of saw runs, but chain does not move	Gear train failure	See authorized service center
Chain does not get oil	<ol style="list-style-type: none">1. Clogged oil slot in guide bar2. Oil is too thick	<ol style="list-style-type: none">1. Remove guide bar and clean oil slot2. Use correct weight of oil. See <i>Filling Oil Tank</i>, page 7
Chain comes off guide bar	<ol style="list-style-type: none">1. Chain is loose2. Guide bar and chain not assembled right	<ol style="list-style-type: none">1. Tighten chain. See <i>Saw Chain Tension Adjustment</i>, page 72. See <i>Assembly</i>, page 6
Saw smokes	Saw damaged. Do not use saw	See authorized service center
Saw leaks oil	Oil cap is not secure	Tighten oil cap. <i>Note:</i> Empty oil tank when not in use

REMINGTON®

ELECTRIC CHAIN SAW

ILLUSTRATED PARTS BREAKDOWN

LNT-2

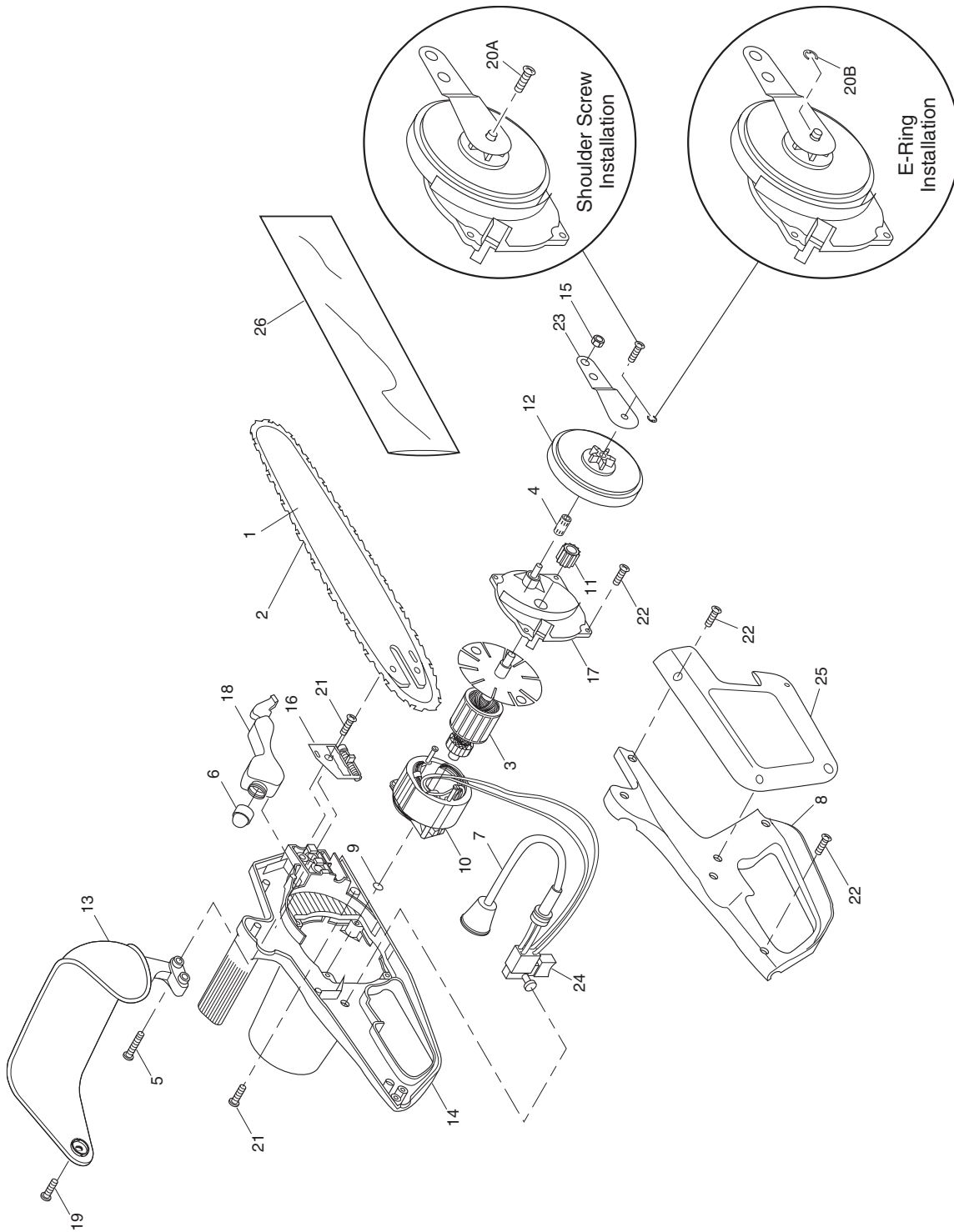

IMPORTANT: Your chainsaw is assembled with EITHER part 20A OR part 20B depending on your saw's design. See illustration above to determine which saw design you have.

OWNER'S MANUAL

PARTS LIST

This list contains replaceable parts used in your chainsaw. When ordering parts, be sure to provide the correct model and serial numbers (from the model plate), then the part number and description of the desired part.

LNT-2

KEY NO.	PART NO.	DESCRIPTION	QTY.		
			099178H	100089-06 100089-08	107709-01 076728K
1	097568-01	Guide Bar, 12"	—	—	1
	097570-01	Guide Bar, 14"	1	1	—
2	091373-02	Saw Chain	—	—	1
	091374-02	Saw Chain	1	1	—
3	107481-01	Armature Assembly	1	1	1
4	075676	Sprocket Roller Bearing	1	1	1
5	076744	Hex-Head Bolt	2	2	2
6	107512-01	Cap & Bulb Assembly	1	1	1
7	099829-01	Cord	1	1	1
8	077399-02	Side Cover, Black	—	1	—
9	076105	Thrust Disk	1	1	1
10	107482-01	Field & Brush Assembly	1	1	1
11	059606	Drive Gear	1	1	1
12	107713-01	Internal Gear	1	1	1
13	106809-01	Front Hand Guard	1	1	1
14	079089-02	Motor Housing, Black	1	1	1
15	NPC-4C	Hex Nut	2	2	2
16	077115	Adjusting Plate Assembly	1	1	1
17	075887	Bearing Plate	1	1	1
18	079086-02	Oil Reservoir	1	1	1
19	097403-01	Pan-Head Screw	1	1	1
20A	076905	Pan-Head Shoulder Screw	1	1	1
20B	108120-01	E-Ring	1	1	1
21	076906	Flat-Head Tap Screw	2	2	2
22	059046	Pan-Head Tap Screw	10	10	10
23	077143	Sprocket Support	1	1	1
24	077525S	Lock-Off Switch	1	1	1
25	106810-01	Sprocket Cover, Black	1	1	1
26	079963-02	Scabbard	—	—	1
	079963-04	Scabbard	1	1	—

IMPORTANT: Your chainsaw is assembled with **EITHER** part 20A **OR** part 20B depending on your saw's design. See illustration on previous page to determine which saw design you have.

REMINGTON®

ELECTRIC CHAIN SAW

ILLUSTRATED PARTS BREAKDOWN

EL-7

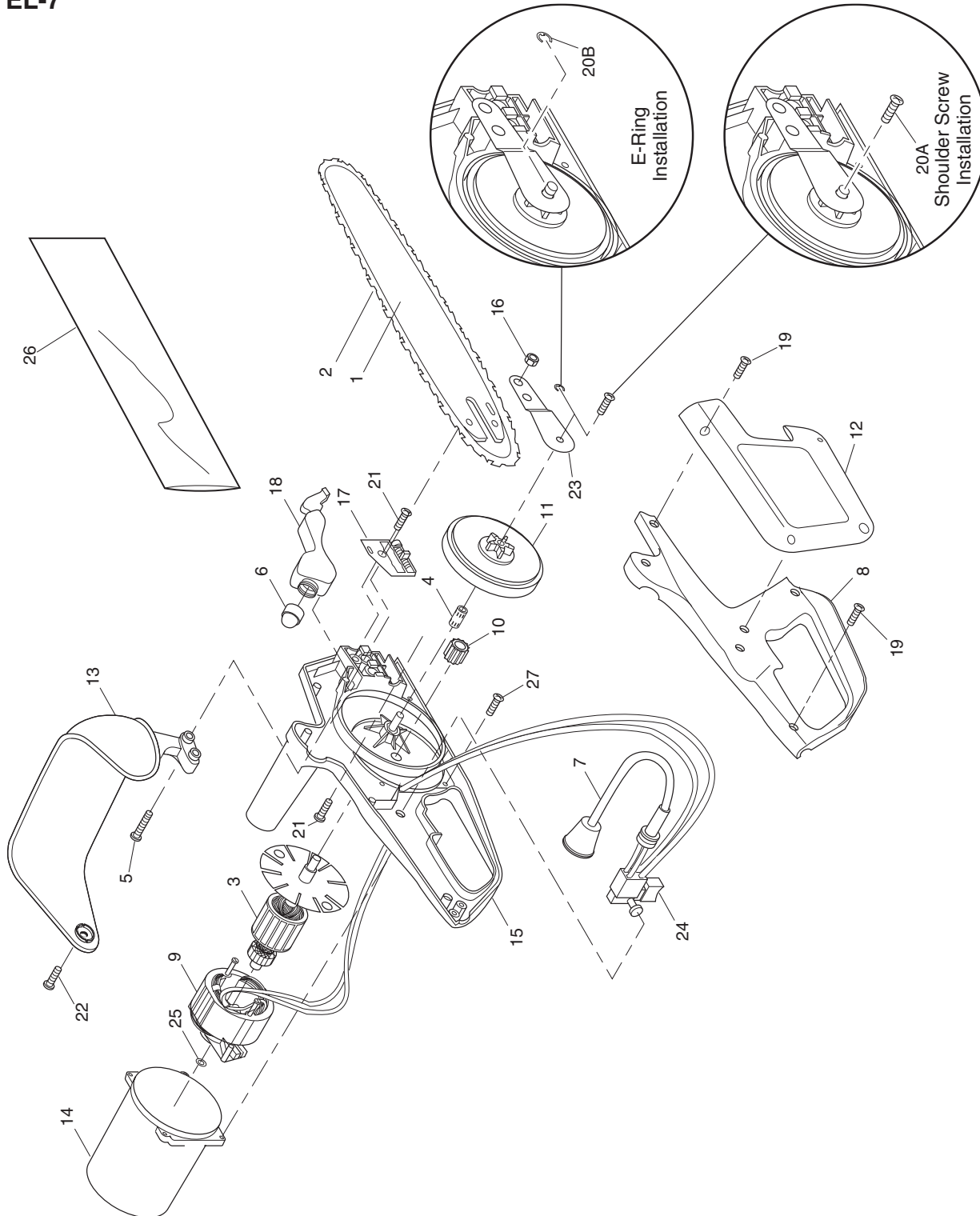

IMPORTANT: Your chainsaw is assembled with EITHER part 20A OR part 20B depending on your saw's design. See illustration above to determine which saw design you have.

OWNER'S MANUAL

PARTS LIST

This list contains replaceable parts used in your chainsaw. When ordering parts, be sure to provide the correct model and serial numbers (from the model plate), then the part number and description of the desired part.

EL-7

KEY NO.	PART NO.	DESCRIPTION	QTY.	
			075762J 100089-07	098031J 099039J 100089-05 107714-02
1	097570-01	Guide Bar, 14"	1	—
	097572-01	Guide Bar, 16"	—	1
2	091374-02	Saw Chain	1	—
	091375-02	Saw Chain	—	1
3	100933-01	Armature	1	1
4	075676	Sprocket Roller Bearing	1	1
5	076744	Hex-Head Bolt	2	2
6	107512-01	Oil Reservoir Cap	1	1
7	099829-01	Cord	1	1
8	077399-02	Side Cover, Black	1	1
9	098042-01	Field	1	1
10	059606	Drive Gear	1	1
11	107713-01	Internal Gear	1	1
12	106810-01	Sprocket Cover	1	1
13	106809-01	Front Hand Guard	1	1
14	076053	Motor Housing Assembly	1	1
15	097034-02	Housing Assembly	1	1
16	NPC-4C	Hex Nut	2	2
17	077115	Adjusting Plate Assembly	1	1
18	079086-02	Oil Reservoir	1	1
19	059046	Pan-Head Tap Screw	6	6
20A	076905	Pan-Head Shoulder Screw	1	1
20B	108120-01	E-Ring	1	1
21	076906	Flat-Head Tap Screw	2	2
22	097403-01	Pan-Head Screw	1	1
23	077143	Sprocket Support	1	1
24	077525S	Lock-off Switch	1	1
25	058059	Thrust Washer	1	1
26	079963-04	Scabbard	1	1
27	059045	Pan Head Tap Screw	4	4
PARTS AVAILABLE - NOT SHOWN				
	079882-01	Hardware Package Includes: 2 - NPC-4C Nuts 2 - 076744 Bolts 1 - 097403-01 Screw	1	1

IMPORTANT: Your chainsaw is assembled with **EITHER** part **20A** **OR** part **20B** depending on your saw's design. See illustration on previous page to determine which saw design you have.

REMINGTON®

ELECTRIC CHAIN SAW

PARTS DEALERS

Ray's Portable Heater Service
3191 Myers Road
Camino, CA 95709-9550
530-644-7716

Baltimore Electric
5 Manila Drive
Hamden, CT 06514-0322
203-248-7553
1-800-397-7553

Eckley's Small Engine
31617 Spruce Drive
Eustis, FL 32726-9592
352-357-6764

Parts Company of America
1657 Shermer Road
Northbrook, IL 60062-5362
708-498-5900
1-800-323-0620
www.grainger.com

Portable Heater Parts
342 North County Road 400 East
Valparaiso, IN 46383-9704
219-462-7441
1-800-362-6951
www.portableheaterparts.com
sales@portableheaterparts.com
techservice@portableheaterparts.com

FBD
1349 Adams Street
Bowling Green, KY 42103-3414
270-846-1199
1-800-654-8534
franktalk@aol.com

Lyons & Lyons Sales Co. Inc.
Glen Arm Road
Glen Arm, MD 21057-9454
410-665-6500
1-800-333-5966
lyonsco@erols.com

Master Part Distributors
1251 Mound Avenue NW
Grand Rapids, MI 49504-2672
616-791-0505
1-800-446-1446
www.masterparts.net

Hance Distributors, Inc.
12795 16th Avenue North
Plymouth, MN 55441-4556
763-559-2299
www.hanceco.com

Automotive Equipment Service
3117 Holmes
Kansas City, MO 64109-1716
816-531-9144
1-800-843-3546
www.aes-lawnparts.com

Bowden Electric Motor Service
1681 S. Wesleyan Blvd.
Rocky Mount, NC 27803
252-446-4203

East Coast Energy
10 East Route 36
West Long Branch, NJ 07764-1501
1-800-755-8809

Forrest Lytle and Sons, Inc.
740 West Galbraith Road
Cincinnati, OH 45231-6002
513-521-1464

Bortz Chain Saw Shop
Road #2, Box 64A
Oley, PA 19547-9412
610-987-6452

21st Century
2950 Fretz Valley Road
Perkasie, PA 18944-4034
215-795-0400
1-800-325-4828

Laportes
2444 N 5th Street
Hartsville, SC 29550-7704
843-332-0191

MTA Distributors
555 Hickory Hills Blvd.
Nashville, TN 37189-9244
615-299-8777
1-800-264-0225

Webbs Appliance Center
1519 Church Street
Nashville, TN 37203-3004
615-329-4079
1-800-899-4079

Industrial Hardware
4109 Bainbridge Blvd.
Chesapeake, VA 23324-1403
804-543-2232
1-800-788-0008
catatem@erols.com

Mills Lawn and Garden
928 Commonwealth Place
Virginia Beach, VA 23464
757-361-9293
www.mills-parts.com

Tuco Industrial Products
5223 180th Street SW
Suite 4A-1
Lynnwood, WA 98037-4506
425-743-9533
1-800-735-1268
www.tucoheat.com

AUTHORIZED SERVICE CENTERS

ALABAMA (AL)

A & O General Repair Service
1470 Opelika Road
Auburn, AL 36830
334-821-7022

Buddy's Small Engine
2500 Triana Blvd.
Huntsville, AL 35805
256-536-9404

Southern Power Tool
2824 Cottage Glen Dr.
Mobile, AL 36693
334-639-8188

ARIZONA (AZ)

Best Brothers Lawnmower Repair
5549 W. Glendale Avenue
Glendale, AZ 85301
602-939-9170

D & L Small Engines, Inc.
10023 North 19th Ave.
Phoenix, AZ 85021
602-861-1978

Power Tool Service Center
660 East 19th Street
Tucson, AZ 85719
520-884-8974

ARKANSAS (AR)

B.G.I. Sales
2918 Willow Road
Jonesboro, AR 72401
870-802-1220
Fax: 870-802-1220

CALIFORNIA (CA)

Ray's Portable Heater Service
3191 Meyers Road
Camino, CA 95709
530-644-7716

California Electric Service
1170-G Burnett Ave.
Concord, CA 94520
925-827-1011
Fax: 925-827-5409

California Electric Service
1208 East Ash Avenue
Fullerton, CA 92631
714-870-0900

J & N Garden Equipment

4460 W. Imperial Hwy.
Inglewood, CA 90304
310-671-0079

Shamay's Enterprises
P.O. Box 3714
58643 Knox-Niman Lane
Landers, CA 92285
760-364-2046

West Coast Contractors Supply
#28 13th Street
San Francisco, CA 94103
415-861-6124

Rincon Valley Yard & Garden

4972 Sonoma Hwy
Santa Rosa, CA 95409
707-593-4124

Power Outdoor Equipment
3160 Industrial Drive
Yuba City, CA 95993
530-671-1871

COLORADO (CO)

Ace Mower and Small Engines
4718 Chromium Drive
Colorado Spring, CO 80918
719-593-0862

Bartell Tool Service
1448 W. Cedar Avenue
Denver, CO 80223
303-777-5463

Metrogas Equipment Company
790 West 64th Ave.
Denver, CO 80221
303-428-3036

Winfrey's Jones LLP
316 18th Street
Greeley, CO 80631
970-353-9576

AAA Electric Company, Inc.
24 South Main Street
Longmont, CO 80501
330-776-6031

Dales Electric Motor Repair
932 Coffman Street
Longmont, CO 80501
303-651-6907

CONNECTICUT (CT)

Baltimore Electronics
5 Manila Ave.
Hamden, CT 06514
203-248-7553
1-800-397-7553

Utility Electric Service
53 Main Street
Hartford, CT 06106
860-246-7271

Goodies Sales and Service
133 Hamilton Street
New Haven, CT 06515
203-865-1470

R & D Services, LLC
790 South Main Street
Plantsville, CT 06479
860-628-5205

FLORIDA (FL)

301 Mower Shop
5724 15th Street E.
Bradenton, FL 34203
941-758-7844

Eckley's Small Engine
31617 Spruce Drive
Eustis, FL 32736
352-357-6764

Bay Lawn Mower Repair
824 Ohio Avenue
Lynn Haven, FL 32444
850-265-1100
Fax: 850-265-0740
baylawnmowerrepair.com

Al's Small Engine, Inc.
2496 Blanding Blvd.
Middleburg, FL 32068
904-282-5472

Tool Doctor
1825 N. Magnolia Ave.
Ocala, FL 34475
352-622-5655

Debary Mower & Repair
1104 Shadick Drive
Orange City, FL 32763
386-775-7505
Fax: 386-775-7758

Lindle & Sons Electric Motor Repair

7016 Hwy. 22
Panama City, FL 32401
850-871-1722

Eustis and Sons, Inc.
7035 66th Street North
Pinellas Park, FL 34665
727-544-1486

A1A Small Engines & Equipment
420 S. Dixie Hwy. E.
Pompano Beach, FL 33060
954-946-5044

Mulvaney's Inc.
2148 W. Tennessee Street
Tallahassee, FL 32304
850-576-5578

A-1 Tool Rental, Inc.
2509 South State Road 7
West Hollywood, FL 33023
954-961-9250

GEORGIA (GA)

Hamilton Hardware
5300 Veterans Pkwy.
Columbus, GA 31904
706-322-6545

Cowan Ace Hardware
1264 Green Street
Conyers, GA 30207
770-483-8818

Able Tool Rental
3360 Fairburn Road
Douglasville, GA 30135
770-949-1932

Douglasville Ace Hardware
6530 Church Street
Douglasville, GA 30133
770-942-7044

Fayette Mower & Appliance
395 S. Glynn St.
Fayetteville, GA 30215
770-461-9400

S & P Rental & Supply Co.
259 Grayson Hwy
Lawrenceville, GA 30245
770-963-0392

Spray Solutions

476 Flowing Wells Rd. D-1
Martinez, GA 30907
706-855-1293

Tifton Electric Motors
1265 US Hwy. 82E
Tifton, GA 31794
912-382-4040

IDAHO (ID)

Rossiter Electric
1501 S. Capitol Ave.
Idaho Falls, ID 83403
208-529-3665

Steam Store Rocky Mountain, Inc.

155 North Gate Mile
Idaho Falls, ID 83401
208-522-0609

J & J Enterprises
1704 Addison Avenue East
Twin Falls, ID 83301
208-733-2001

ILLINOIS (IL)

Uline Lawn Equipment
290 W. Squk Trail
Chicago Heights, IL 60411
708-755-2227
708-755-1533 (Fax)

Lange Electric
912 E. Fayette
Effingham, IL 62401
217-347-7626

Carter's Small Engine Repair
206 N. Hickory Street
Galatia, IL 62935
618-268-4814

H & R Pump Company, Inc.
2111 E. Washington Street
Joliet, IL 60434
815-726-2950

INDIANA (IN)

Hutchens Sales and Service
R.R. #5, Box 550
Bloomfield, IN 47424
812-876-1891

OWNER'S MANUAL

Nichols Ice & Oil
2018 Park Road
Connersville, IN 47331
765-825-3741

B & W Repair Service
213 N. Main Street
Dale, IN 47523
812-937-2576

Industrial Motor & Electrical
Supply, Inc.
64466 State Road 19
Goshen, IN 46526
219-862-4044

Tyrie Mower Repair
110 South 16th Street
Lafayette, IN 47905
765-742-7886

Kabelin True Value Hardware
512 Andrew Avenue
Laporte, IN 46350
219-362-7917

Lear Lawn & Garden
2204 N. Wolfe Street
Muncie, IN 47303
765-282-6273

Li'l Engine Sales & Service, Inc.
1428 Vincennes Street
New Albany, IN 47150
812-944-1377

Portable Heater Parts
342 North County Road, 400 East
Valparaiso, IN 46383
219-462-7441

D W Handy's
217 West 15th St.
Vincennes, IN 47591
812-886-0172

New Paris Farm Store
68443 W. Main Street
P.O. Box 96
New Paris, IN 46553
219-831-4823

IOWA (IA)

Beal's Motor Rewinding
600 West Beach
Cherokee, IA 51012
712-225-6173

Blink Electric Motors
Rear 116 N. 1st Ave.
Marshalltown, IA 50158
641-752-3036

Northeast Iowa Motor Service
24665-150th Street
Sumner, IA 50674
563-578-5883

Black Hawk Rental
324 West 15th Street
Waterloo, IA 50702
319-234-4421

KANSAS (KS)

Abilene Rent-All & Sales
1701 West 1st Street
Abilene, KS 67410
785-263-7668

NAAB Electric, Inc.
2013 W. Jones
Garden City, KS 67846
316-276-8101

Morris Electric Repair
2423 5th Street
Great Bend, KS 67530
316-792-2919

McPherson Rental Center
911 West First Street
McPherson, KS 67460
620-241-3333

KENTUCKY (KY)

Gillum's Service & Repair
8611 Rt. US 60
Ashland, KY 41102
606-928-4932

E-Z Rent It Inc.
1428 U.S. 31-W By-Pass
Bowling Green, KY 42101
270-782-9462

Roman's Repair Shop
601 College Street
Bowling Green, KY 42101
270-746-0857

Hopkinsville Electric Motor
704 W. 15th Street
Hopkinsville, KY 42240
270-886-7585

Rental World, Inc.
9509 Dixie Hwy.
Louisville, KY 40272
502-935-8853

All States Industrial Repair
728 E. Center Street
Madisonville, KY 42431
270-821-6555

D & C Rental & Sales
84 Keystone Drive
P.O. Box 797
Mayfield, KY 42066
270-247-9000

LOUISIANA (LA)

Triangle Bicycle and Lawnmower
5433 Crowder Road
New Orleans, LA 70127
504-241-3239

Wayne's Heat & Air
1605 W. Vine Street
Opelousas, LA 70570
337-948-4246

Evans of LA, Inc.
907 Cypress Street
West Monroe, LA 71291
318-322-6180

MAINE (ME)

Richard's Electric Motor
549 Main Street
Caribou, ME 04736
207-498-8950

Roger's Electric Motor Shop
823-West Main Street
Madawaska, ME 04756
207-728-4253

Rent-N-Save
28 Allen Avenue
Portland, ME 04103
207-797-2223

MARYLAND (MD)

Center Supply Company
6802 Industrial Drive #208
Beltsville, MD 20705
301-595-0860

Lehmans Hardware, Inc.
5921 Belair Road
Baltimore, MD 21206
410-483-5888

Norris Taylor Contractors, Inc.
8480 Ocean Gateway
Easton, MD 21601
410-822-2050

Lyons & Lyons Sales Co. Inc.
Glen Arm Road
Glen Arm, MD 21057-9454
410-665-6500
1-800-333-5966
lyonsco@erols.com

Chesapeake Rent All
210 N. Stokes Street
Havre De Grace, MD 21078
410-939-1720

B & M Sharpening & Repair
8614 Church Lane
Randalstown, MD 21133
410-655-0801

MASSACHUSETTS (MA)

Ormond's Inc.
115R Dean Ave.
Franklin, MA 02038
508-528-2013

Beacon Lumber/Beacon Rental
513 Church Street
New Bedford, MA 02745
508-995-1766

Mott's Tool Repair Service
92 Rayber Road
Orleans, MA 02653
508-240-0764

Utility Electric Service #2
810 Main Street
Springfield, MA 01105
413-781-1635

MICHIGAN (MI)

R & A Service
12900 Haggerty Road
Belleville, MI 48111
734-697-1144

Thompson's Rental Resale Repair
11973 New Lothrop Road
Byron, MI 48418
810-266-4969

Hendricks Sales
7876 Division
Grand Rapids, MI 49548
616-455-8220

Chicago Drive Rentals, Inc.
11298 Chicago Drive
Holland, MI 49424
616-396-9575

Fowler's Farm City Sales
2876 West Washington Road
Ithaca, MI 48847
989-875-3976

Superior Industrial Sales & Service
116 N. State Street
Jackson, MI 49201
517-784-0539

Norm's Electric Motor Repair
414 Walbridge Street
Kalamazoo, MI 49007
616-382-5054

A & J Rentals
550 S. 11th Street
Niles, MI 49120
616-684-3200

Bob's Service Shop
2537 W. Drahnner Road
Oxford, MI 48371
248-628-2601

Bid's Service, Inc.
11276 E. Ten Mile
Warren, MI 48089
586-759-3040

MINNESOTA (MN)

Perry's Electrical Rebuilders
24664 Hale Avenue
Forest Lake, MN 55025
651-464-8054

Andy's Small Engine City
2408 Pearl Ct. SE
Rochester, MN 55904
507-280-0373

Reed's Sales & Service
1260 Payne Ave.
St. Paul, MN 55101
651-774-9515

MISSISSIPPI (MS)

Handy Man Rentals
1904 Shiloh Road
Corinth, MS 38834
662-287-2460

MISSOURI (MO)

Stewarts Enterprises
7631 NW Salebarn Road
Cameron, MO 64429
816-632-6578

B & J Repair Service
21504 Blue Mills Rd.
Independence, MO 64058
816-796-6476

Northwest Power Sales
26848 Haultain Drive
Maryville, MO 64468
660-582-5080

Buchheit, Inc.
Route 7, Box 239
Perryville, MO 63775
573-547-1017

A K Small Engine Works
15726 Hwy C
Versailles, MO 65084
573-378-6339

MONTANA (MT)

Tom's Service Repair
1111-6th Avenue North
Billings, MT 59101
406-259-6179

Mosch Electric Motors, Inc.
2513 - 17th St. NE
Black Eagle, MT 59414
406-453-2481

Sun Rental Center
1301 - 3rd St. NW
Great Falls, MT 59404
406-761-6688

NEBRASKA (NE)

Hatten's Electric Service
130 S. Hastings, Box 843
Hastings, NE 68901
402-463-4596

Craft Specialties
201 Pine St.
Haddar, NE 68738
402-379-3129

Flohr Electric Motor
4356 South 90th Street
Omaha, NE 68127
402-331-6863

MSE Parts Unlimited
4935 South 136th Street
Omaha, NE 68137
402-895-0806

Ted's Mower Sales and Service, Inc.
5155 Q. Street
Omaha, NE 68117
402-731-7058

LaVern Hass Repair
1204 - 1st Road
Wisner, NE 68791
402-529-6846

NEW HAMPSHIRE (NH)

Kingston Enterprises
85 North Road
Kingston, NH 03848
603-642-3506

NEW JERSEY (NJ)

Associated Industries
2433 Rt. 206
Eiastampton, NJ 08060
609-267-8417

Woodchuck's Lawnmower
and Appliance
220 Whitehorse Pike
Magnolia, NJ 08049
856-783-1111

Tep's Power Equipment
1002 N. High Street
Millville, NJ 08332
856-825-8294

Richard's Sharpening Service
824 Mill Road
Northfield, NJ 08225
609-641-9481

Capitol Service & Equipment
551 New Market Road
Piscataway, NJ 08855
732-968-5577

NEW YORK (NY)

Valley Mower Service
2857 Ellis Creek Road
Barton, NY 13734
607-589-4825

White Tool Supply Inc.
3047 Atlantic Avenue
Brooklyn, NY 11208
718-227-8844

Lehman's Farm & Home Supply
Route 26
Denmark, NY 13631
315-493-1151

M & S Repair Shop
303 Hilltop Drive
Elma, NY 14059
716-652-0311

Luther's Outdoor Equipment
3676 State Route 5
Frankfort, NY 13340
315-894-4467

Crossbay Appliance Service
158-34 Crossbay Blvd.
Howard Beach, NY 11414
718-843-4422

Provenzano's
84 E. Main Street
Kings Park, NY 11754
631-269-1080

The Warranty Center
16 Church Street
Kings Park, NY 11754
631-269-9057

Para-Deys Tools
708 Victor Road
Macedon, NY 14502
315-986-2520

Allstar Power Equipment
460 East 3rd Street
Mount Vernon, NY 10553
914-668-6252

P & C
12 East Street
Nunda, NY 14517
716-468-5050

Otega Repair
226 County Hwy 7
Otego, NY 13825
607-988-7859

Owego Agway Coop
38 West Avenue
Owego, NY 13827
607-687-2039

Jack-n-Heater Service
185 Beartown Road
Painted Post, NY 14870
607-962-1239

Larmon Small Engine
16353 Co. Rt. 91
Pierrepont Manor, NY 13674
315-465-6671

R & D Mower & Snowblower
Sales and Service
1632 Empire Blvd.
Webster, NY 14580
716-671-9409

REMINGTON®

ELECTRIC CHAIN SAW

NORTH CAROLINA (NC)

Leonard Electric Motor Repair, Inc.
531 N. Fayetteville Street
Asheboro, NC 27203
336-625-2375

Martin Equipment Company
4209-B US 70 E.
Goldsboro, NC 27534
919-778-5996

Hickory Home & Garden
336 HWY 321 NW
Hickory, NC 28601
704-327-3719

Billtang USA Interstate Supplies
511 Union West Blvd.
Stallings, NC 28104
704-893-2878
Fax: 704-893-0442
iss-go.com

O'Mary's Small Engine
220 W. Forlines Road
Winterville, NC 28590
252-355-4597

NORTH DAKOTA (ND)

Fix-It Shop
316 21st Street E.
Dickson, ND 58601
701-225-0766

Ted's Saw Service
901 South 12th Street
Grand Forks, ND 58201
701-775-7343

Craig's Small Engine Repair
508 East 2nd Street
Williston, ND 58801
701-774-0798

OHIO (OH)

Carter Electrical Repair
3448 Lunar Road NE
Carrollton, OH 44615
330-627-4061

North East Mower Service
412 East 156th Street
Cleveland, OH 44110
216-531-8197

Lefeld Welding & Steel Supply
600 N. Second Street
Coldwater, OH 45828
419-678-2397

Dayton Hardware & Supply
16-32 N. Irwin Street
Dayton, OH 45404
513-258-3721
1-800-762-3426 Ohio only

Ken's Repair
3246 S. Sectionline
Delaware, OH 43015
740-369-4798

Anytool & Outdoor Power Equip.
21150 Lorain Road
Fairview Park, OH 44126
440-356-1920

Deep Run Mower Service
58781 Heil Addn. Deep Run
Martins Ferry, OH 43935
740-859-6131

Worcester Sales and Service
34200 Lorian Road
N. Ridgeville, OH 44039
440-327-2196

Leonard Hardware
145 North 15th Street
Sebring, OH 44672
330-938-6329

Sparks Sales & Service
5184 Fletcher Chapel Road
Springfield, OH 45502
937-323-5925

United Rentals of North America
5745 Angola Road
Toledo, OH 43615
419-865-5539

OKLAHOMA (OK)

Kay Electric Company
1101 W. Broadway
P.O. Box 635
Altus, OK 73522
580-482-1757

Sooner Distributors
3021 S. High Street
Oklahoma City, OK 73143
405-634-3391

H. L. Moss
1714 E. 15th Street
Tulsa, OK 74104
918-744-1305

OREGON (OR)

Turner's Lawnmower and Saw
728 SE Robin Way
Gresham, OR 97080
503-665-5441

Pendleton Grain Growers
200 S. 1st Street
Hermiston, OR 97801
541-567-5591

Appliance Repair Central
3203 NE Sandy Blvd.
Portland, OR 97232
503-234-7339

PENNSYLVANIA (PA)

General Rental & Sales Center
P.O. Box 810
Old Rt 1 & 41
Avondale, PA 19311
610-268-2825

Bud's Tractor and Mower Service
21 Bock Lane
Baden, PA 15005
724-869-7142

Engine Doctors
20 Russell Blvd.
Bradford, PA 16701
814-362-3091

Pro-Fix
136 Narrows Road
Edwardsville, PA 18651
570-288-0476

Four All Seasons
641 N. Mountain Road
Harrisburg, PA 17112
717-545-5114

Carson's Hardware
637-43 Main Street
Hellertown, PA 18055
610-838-7741

Al Muccioli's Service
2001 Bedford Street
Suite C
Johnstown, PA 15904
814-266-5734

O'Valray Nurseries Inc.
R.D. #8, Box 362
Kittanning, PA 16201
724-548-1579

Hillyard Equipment Service Center
633 Lausch Lane
Lancaster, PA 17601
717-569-5768

Petrosky's Hardware & Supply Co.
602 Alexandria Street
Latrobe, PA 15650
724-537-3541

Raymond, M. Nolt
290 S. Shirk Road
New Holland, PA 17557
717-354-0198

Snyder Electric Company
1500 Chateau Street
Pittsburgh, PA 15233
412-231-3100

Stamm's Mower Repair
Rd. 5, Pine Lane Box 150
Selinsgrove, PA 17870
570-743-7651

SOUTH CAROLINA (SC)

Hall's Small Motor Repair
225 Heathwood Drive
Aiken, SC 29803
803-649-6313

Todd's Electric Motor Repair
110 Laurel Street
Conway, SC 29526
843-248-2444

Laportes
2444 N. 5th Street
Hartsville, SC 29550
843-857-0222

TENNESSEE (TN)

Vista Small Engine
1510 Vista Lane
Clarksville, TN 37043
931-552-6953

Master Repair Service
239 Elmore Road
Crossville, TN 38555
931-484-2061

The Speciality Shop
2300 East Magnolia Avenue
Knoxville, TN 37917
865-523-6894

Authorized Equipment Service
812 Polk Avenue
Memphis, TN 38126
901-774-0850

Webb's Appliance Service Center
1519 Church Street
Nashville, TN 37203
615-329-4079

TEXAS (TX)

Brunson Feed Mill
709 Sealy Ave.
Ballinger, TX 76821
915-365-2419

Bud's LP Gas & Supply
225 Grand
Channelview, TX 77330
713-457-2456

Corpus Christi Power Tool & Rpr.
3701 Agnes
Corpus Christi, TX 78405
361-883-1117

Freel Enterprise
118 Elston
Dallas, TX 75232
214-376-9913

Southwest Electric Service
3008 Canton St.
Dallas, TX 75226
214-742-8211

Powell's Small Engine Service
5906 Hwy 66
Greenville, TX 75402
903-454-1877

Houston Lawnmower & Saw Works
620-1/2 W. 19th Street
Houston, TX 77008
713-864-9269
Fax: 713-864-9338

Ray DeSpain's Inc.
P.O. Box 184, Loop 494 North
New Caney, TX 77357
281-689-2121
Service Department

James Lawnmower Sales
5034 Rigsby
San Antonio, TX 78222
210-648-0182
Fax: 210-648-3636

UTAH (UT)

Roosevelt Service Center
P.O. Box 1308
133 South 3rd East
Roosevelt, UT 84066
435-722-2119

Appliance Service Center
1475 S. Main Street
Salt Lake City, UT 84115
801-467-6361

Tooele Valley Sales & Service
398 N. Main Street
Tooele, UT 84074
435-882-8180
Fax: 435-882-8181

VERMONT (VT)

Brown and Roberts
182 Main Street
Brattleboro, VT 05301
802-257-4566

VIRGINIA (VA)
Industrial Hardware
4109 Bainbridge Blvd.
Chesapeake, VA 23324
804-543-2232

Warren E. Smith Shops
406 Cambria Street
Christiansburg, VA 24073
540-382-5501

B & B Appliance & Lawn Equipment
71 Lawson Road SE Suite C
Leesburg, VA 22075
703-777-1093

Roberts Small Engine Repair
1109 Curve Road
Pearisburg, VA 24134
540-921-3255

Outdoor Power Equipment
1136-40 Myrtle Street
Suffolk, VA 23434
757-925-4933

Mills Repair Service
928 Commonwealth Place
Virginia Beach, VA 23464
757-361-9293

WASHINGTON (WA)

Action Small Appliance Service
1500 - 145th Place SE
Bellevue, WA 98007
425-643-9806

TUCO Industrial Products
5223 - 180th SW Suite 4A-1
Lynnwood, WA 98037
425-743-9533

Action Small Appliance
2125 Second Avenue
Seattle, WA 98121
206-448-2020

Lifficks Electric Shop
8239 S. Park Avenue
Tacoma, WA 98408
253-474-7403

WEST VIRGINIA (WV)

Beckley Mower Service
405 Prince Street
Beckley, WV 25802
304-253-5748

Raymond's Service Center
Route 65
Delbarton, WV 25670
304-475-2855

Town and Country Supply
4117 First Avenue
Nitro, WV 25143
304-755-3520

WISCONSIN (WI)

Smith Petroleum Ltd.
217 N. Walworth
Darien, WI 53114
262-724-3206

Ohnstad Power Equipment
12012 Center Hill Road
Darlington, WI 53530
608-776-3802

Bob's Engine Shop
513 S. Military Road
Fond Du Lac, WI 54935
920-921-2841

Reliance Electric Motors
1621 Livingstone Road
Hudson, WI 54016
715-386-3633

Kewaunee Small Engine
E2068 State Hwy 29
Kewaunee, WI 54216
920-388-2604

Ken's Economy Sales
8887 Highway A
Marshfield, WI 54449
715-676-2143

Cliff's Tractor Place
Hwy 35-133
P.O. Box 76
Patch Grove, WI 53817
608-994-2354

Barton Small Engine
1628 N. Main Street
West Bend, WI 53090
262-334-5373

OWNER'S MANUAL

REPLACEMENT PARTS AND ACCESSORIES

Purchase these accessories and parts from your nearest dealer or service center. If they can not supply these accessories or parts, either contact your nearest Parts Dealer or DESA Specialty Products™ for referral information. Parts dealers are listed in this manual.

LNT-2

Part Number	Description
104302-01S#	Guide bar, 8"
104301S#	Chain, 8"
097567-01S	Guide bar, 10"
091371S	Chain, 10"
097568-02S	Guide bar, 12"
091373-02S	Chain, 12"
107713-01	Drive sprocket

099178H, 100089-06, 100089-07, 100089-08, & EL-1

Part Number	Description
097570-01S	Guide bar, 14"
091374-02S	Chain, 14"
107713-01	Drive sprocket

Must order both pieces.

 **WARNING:** Use only replacement parts and accessories described in this manual. Use of other parts or accessories could damage saw or injure operator.

You can also visit our technical service web site at www.desatech.com.

DESA Specialty Products™
P.O. Box 90004
Bowling Green, KY 42102-9004
1-800-858-8501

EL-7, 098031J, 099039J, 100089-04, 100089-05

Part Number	Description
097572-03S	Guide bar, 16"
091375-02S	Chain, 16"
107713-01	Drive sprocket

POLE SAW, 104316-04 (8") POLE SAW ASSEMBLY, 104317

Part Number	Description
104302-01S	Guidebar, 8"
104301S	Chain, 8"
107713-01	Drive Sprocket

POLE SAW, 106890-01 (10") POLE SAW ASSEMBLY, 106821

Part Number	Description
097567-01S	Guidebar, 10"
091371S	Chain, 10"
107713-01	Drive Sprocket

General

Part Number	Description
079963-02	Plastic scabbard, 8" & 10"
079963-04	Plastic scabbard, 12", 14", & 16"
106809-01	Hand Guard
077155	Adjusting Plate Assy.

REPAIR SERVICE

Note: Only use original replacement parts. This will protect your warranty coverage for parts replaced under warranty.

Each authorized service center is independently owned and operated. For additional service center or warranty information, call 1-800-858-8501 or visit our technical service web site at www.desatech.com.

WARRANTY SERVICE

If saw requires warranty service, return it to nearest authorized service center. You must show proof of purchase. If faulty materials or workmanship caused damage, we will repair or replace saw without charge.

NON-WARRANTY SERVICE

If saw requires service, return it to nearest authorized service center. Repairs will be billed to you at regular repair list prices. **Note:** Normal wear, misuse, abuse, neglect, or accidental damage is not covered under warranty.

Model _____
Date Purchased _____

ELECTRIC CHAIN SAW LIMITED WARRANTY

Always specify model and serial numbers when writing the factory.

We reserve the right to amend these specifications at any time without notice. The only warranty applicable is our standard written warranty. We make no other warranty, expressed or implied.

DESA Specialty Products™ warrants this electric chain saw and any parts thereof, to be free from defects in material and workmanship for one year (90 days for reconditioned unit) from the date of first purchase from an authorized dealer, provided that the product has been properly maintained and operated in accordance with all applicable instructions. The bill of sales or proof of purchase must be presented at the time a claim is made under this warranty.

This warranty is extended only to the original retail purchaser. This warranty covers only the parts and labor required to restore this chain saw to its proper operating condition. Warranty parts must be obtained through factory authorized dealers and service centers for this product. These dealers and service centers will provide original factory replacement parts. Failure to use original factory replacement parts voids this warranty.

This warranty does not cover commercial, industrial, or rental usage, nor does it apply to parts that are not in original condition because of normal wear and tear, or parts that fail or become damaged as a result of misuse, accident, lack of proper maintenance, tampering, or alteration. Travel, handling, transportation, and incidental costs associated with warranty repairs are not reimbursable under this warranty and are the responsibility of the owner.

To the full extent allowed by the law of the jurisdiction that governs the sale of the product, this express warranty excludes any and all other expressed warranties and limits the duration of any and all implied warranties, including warranties of merchantability and fitness for a particular purpose to one year from the date of first purchase, and DESA Specialty Products™ liability is hereby limited to the purchase price of the product and DESA Specialty Products™ shall not be liable for any other damages whatsoever including indirect, incidental, or consequential damages.

Some states do not allow limitation of how long an implied warranty lasts or an exclusion or limitation of incidental or consequential damages, so the above limitation of damages may not apply to you.

This warranty provides the original purchaser with specific rights. For information regarding those rights, please consult the applicable state laws.



P.O. Box 90004
Bowling Green, KY 42102-9004
www.desatech.com